



"Pure Lead" Sealed Lead Acid Aviation Battery

25 Ah



Hawker sealed aircraft batteries have been designed for high power and long life, thereby meeting a wide variety of civil and military requirements. Hawker's unique pure lead grids and recombination technology ensure long shelf life and fast recharge capabilities.

All of Hawker's aviation battery products are classified as non-hazardous and unrestricted for land, sea, or air transportation when correctly packed. This battery needs no regular maintenance, has no memory effect, and doesn't suffer from fading. Depending on operation and use, the battery can be up to a 5 year fit and forget.

Applications:

- | | |
|--------------------------|----------------------|
| BAe 146/Avro 146 | Jetstream 3100/3200 |
| BAC 1-11 | Westland EH-101 |
| Britten-Normand Islander | Fairchild 26/226/227 |
| Hawker 800XP | |

Advantages:

- Full Replacement Warranty
 - 30 months after installation
 - 24 months storage prior to installation
- Completely Sealed and Maintenance Free
 - No deep cycling is ever required.
 - No memory characteristics.
 - No filling of water or acid.
 - Non-spillable.
 - No charging is required when storing the battery on the shelf for up to two years at 25°C or less.
 - Battery dispatched from manufacturers plant fully charged.
 - Battery requires only an "open circuit voltage" check prior to fit.
- Recovers From Deep Discharge

The main current carrying structures inside a Hawker battery are constructed of pure lead-tin plates. Because of the purity of the lead, Hawker SLA batteries do not exhibit typical characteristics of Lead-Calcium and Lead- Antimony batteries. Hawker SLA batteries have exceptional charge retention and superb deep discharge recovery.
- High Capacity

Hawker's unique manufacturing process produces plates that are very thin – .7mm thick as opposed to the 2-4mm thick plates common to most lead-calcium SLA batteries. Thinner plates mean each cell can contain more plates with- out increasing the overall size or weight of the battery. More plates means the Hawker battery contains a much higher surface area contact between the positive and negative active materials, resulting in a very high discharge rate and recharge capacity.

30-month full replacement warranty

Certifications:

FAA-PMAd for replacement of:

- Saft 2376
- AeroDesign AD-9750P0640
- Concorde RG390E
- Hawker 9750E0640

Visit www.securaplane.com for details.



Hawker
25 Ah

Part Number
9750W0640



"Pure Lead" Sealed Lead Acid Aviation Battery

25 Ah

SPECIFICATIONS:

Model Number:

9750W0640x

Size:

9.5" x 11.9" x 8.9"

DC Connector:

MS18093/MS3509

Qual:

DO-160C

Weight:

27 kg (59.5 lb)

Nominal Voltage:

24V

Nominal Capacity:

27Ah

Transportation:

Non-hazardous and unrestricted when securely packed and protected against short circuit.

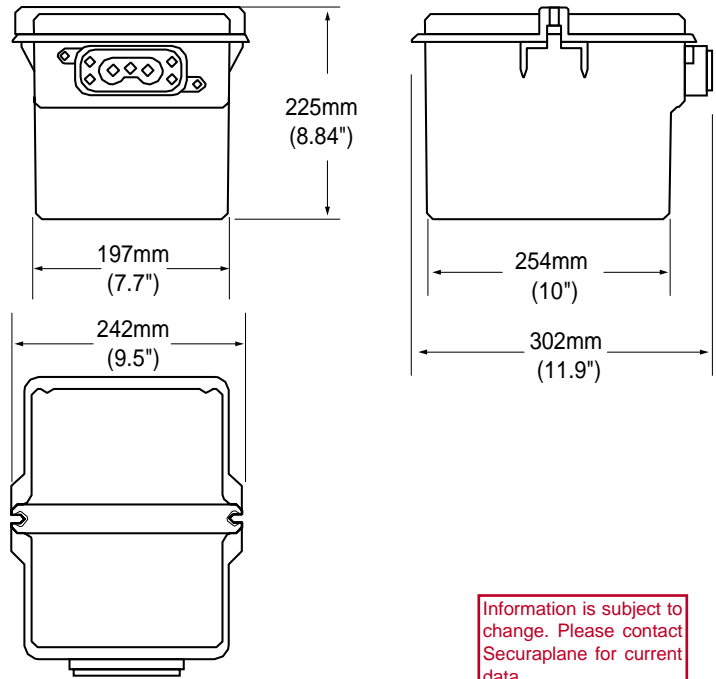

STORAGE OF UNCOMMISSIONED PRODUCT

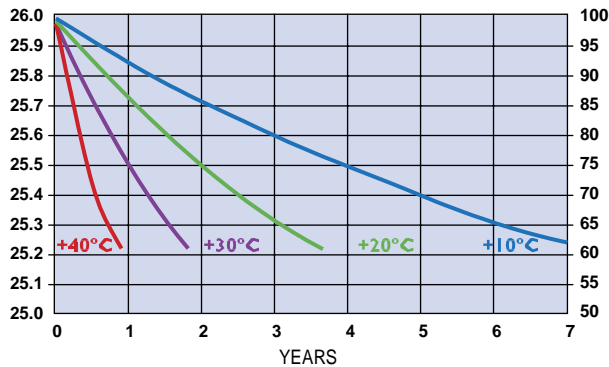

CHARGE ACCEPTANCE BS 6G 205 Clause 8.11

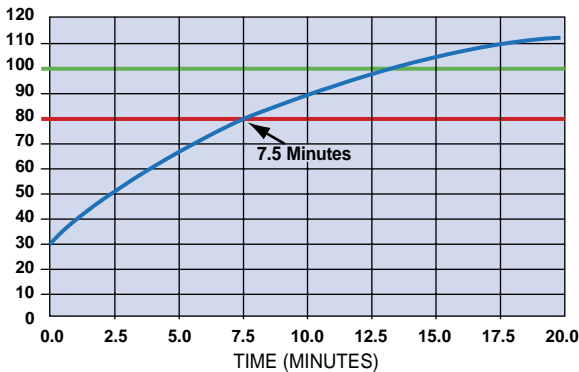

POWER RATING

Testing of Group B sample to Batspec 210 clause of 3.9 and IEC 952-1 clause 6
Test Reference PDTR 1817 - June 1998

