



securaplane
TECHNOLOGIES INC

40 Ah

750W0538 Battery



Dassault Falcon Jet in partnership with **Securaplane Technologies** is pleased to announce that an STC has been granted to install Hawker 40 Ah "Pure Lead" sealed lead acid batteries on the Falcon 50/50EX aircraft.

Hawker sealed aircraft batteries have been designed for high power, long life, and low maintenance, thereby meeting a wide variety of civil and military requirements. Hawker's unique pure lead grids and patented gas recombination technology ensure long shelf life

and fast recharge capabilities.

All of Hawker's aviation battery products are classified as non-hazardous and unrestricted for land, sea, or air transportation when correctly packed. This battery requires no regular maintenance, has no memory effect, and doesn't suffer from fading. Depending on type of operation and useage, the battery can provide up to a 5 year life.

Advantages:

- **Full Replacement Warranty**

- 24 months storage prior to installation, *plus*
- 30 months after installation

- **True no-maintenance battery.**

- **Recovers From Deep Discharge**

The main current carrying structures inside a Hawker battery are constructed of pure lead-tin plates. Because of the purity of the lead, Hawker SLA batteries do not exhibit typical characteristics of Lead-Calcium and Lead-Antimony batteries. Hawker SLA batteries have exceptional charge retention and unsurpassed deep discharge recovery.

- **High Capacity**

Hawker's unique manufacturing process produces plates that are very thin – .7mm thick as opposed to the 2-4mm thick plates common to most lead-calcium SLA batteries. Thinner plates mean each cell can contain more plates without increasing the overall size or weight of the battery. More plates means the Hawker battery contains a much higher surface area contact between the positive and negative active materials, resulting in a very high discharge rate, very high recharge capacity, and virtual immunity to "thermal runaway".

- **Battery block replacement** at significantly less than the list price of a new battery. This can extend the life of the battery indefinitely.

- **Shipped fully charged and ready to install.**

*For further information, please contact
Dassault Falcon Jet or Securaplane:*

- **Certification:**

The Hawker 9750W0538 battery is STC'd and PMA'd for installation on the Falcon 50/50EX

- **Hot and cold performance far exceeding that of any other aviation battery.**

- Cold — 50% more cranking amps of any other equivalent-rated aviation battery at -40° C/F
- Hot — Designed for hot weather operation with an expected battery life of 3 years at 40° C average temperature.



Part Number
9750W0538





"Pure Lead" Sealed Lead Acid Main Ship Battery

40 Ah

SPECIFICATIONS:

Part Number:

9750W0538

Size:

11.05" x 11.97" x 10.4"

DC Connector:

MS18093/MS3509

Qual:

DO-160D

Weight:

38 kg (83.8 lb)

Nominal Voltage:

24V

Nominal Capacity:

40Ah

Transportation:

Non-hazardous and unrestricted when securely packed and protected against short circuit.

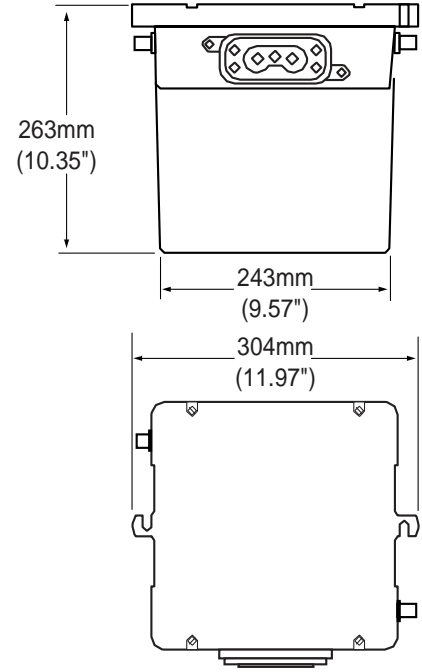
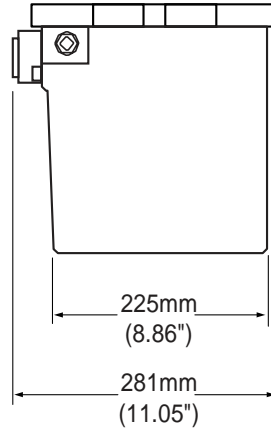

PERFORMANCE CURVES:

STORAGE OF UNCOMMISSIONED PRODUCT

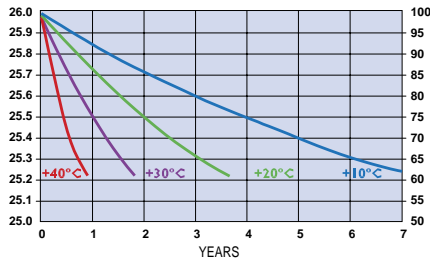

CHARGE ACCEPTANCE BS 6G 205 Clause 8.11

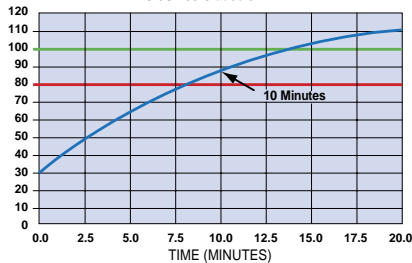

POWER RATING Testing of Group B sample to Batspec 210 clause of 3.9 and IEC 952-1 clause 6 Test Reference PDTR 1817 - June 1998

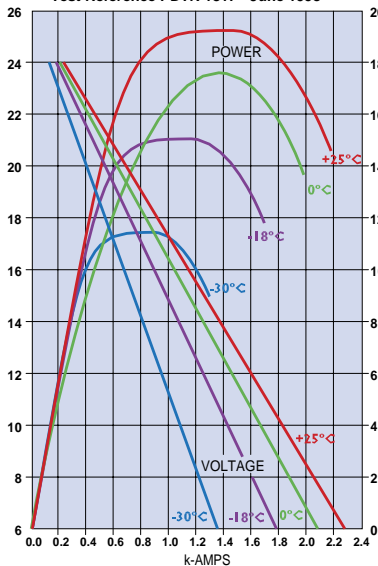

EASY REBLOCKING:



Internal monoblocks can be replaced at significant savings over the replacement cost of a new battery.