



"Pure Lead" Sealed Lead Acid Aviation Battery

43 Ah



Now Available for

Cessna 500, 501, 550, 551 & 560 Series Aircraft

Hawker sealed aircraft batteries have been designed for high power, long life, and low maintenance, thereby meeting a wide variety of civil and military requirements. Hawker's unique pure lead grids and high percentage (99.5%) recombination technology ensure long shelf life and fast recharge capabilities.

All of Hawker's aviation battery products are classified as non-hazardous and unrestricted for land, sea, or air transportation when correctly packed. This battery needs no regular maintenance, has no memory effect, and doesn't suffer from fading. Depending on operation and use, the battery can provide up to a 5 year life before reblocking.

Advantages:

- **Specifically designed for Cessna 500 Series Aircraft**
 - Direct form-fit-function replacement for existing Ni-Cad or Lead Acid batteries
- **Full Replacement Warranty**
 - 24 months storage prior to installation, *plus*
 - 30 months after installation
- **Hot and cold performance far exceeding that of any other aviation battery.**
 - Cold — 50% more cranking amps of any other equivalent-rated aviation battery at -40° C/F
 - Hot — Designed for hot weather operation with an expected battery life of 3 years at 40° C average temperature

- **True no-maintenance battery.**

- **Recovers From Deep Discharge**

The main current carrying structures inside a Hawker battery are constructed of pure lead-tin plates. Because of the purity of the lead, Hawker SLA batteries do not exhibit typical characteristics of Lead-Calcium and Lead-Antimony batteries. Hawker SLA batteries have exceptional charge retention and superb deep discharge recovery.

- **High Capacity**

Hawker's unique manufacturing process produces plates that are very thin – .7mm thick as opposed to the 2-4mm thick plates common to most lead-calcium SLA batteries. Thinner plates mean each cell can contain more plates without increasing the overall size or weight of the battery. More plates means the Hawker battery contains a much higher surface area contact between the positive and negative active materials, resulting in a very high discharge rate and recharge capacity.

- **Battery block replacement** at significantly less than the list price of a new battery.

- **Shipped fully charged and ready to install**

- **Steel Case**

Epoxy coated steel case, including thermal sensor

Certifications:

Hawker 43 Ah series batteries are STC'd and PMA'd for installation on these aircraft:

- Cessna Citation I, II, V, Bravo, Ultra, Encore
- Falcon 2000, 2000EX
- Bombardier CRJ-100, -200
- Dash-8
- Gulfstream III, IV
- King Air 100, 200, 90 Series
- Beechjet 400, 400A, 400T (STC project open)
- Boeing 747-100, -200, -300, SP (STC project open)

30-month full replacement warranty



Hawker 43 Ah

Part Number 9750W0370-11





"Pure Lead" Sealed Lead Acid Aviation Battery

43 Ah

SPECIFICATIONS:

Size:

9.99" x 9.72" x 10.75"

Special Mounting:

Per customer requirements

DC Connector (J1): MS18093/MS3509

Temperature Sensor Connector (J2):

M83723/73R1212

Thermistor

Nominal 2700 Ohm $\pm 5\%$ @ +25°C

Qual:

DO-160C

Weight:

91 lb. (41.28 kg)

Nominal Voltage:

24V

Nominal Capacity:

43Ah

Transportation:

Non-hazardous and unrestricted when securely packed and protected against short circuit.

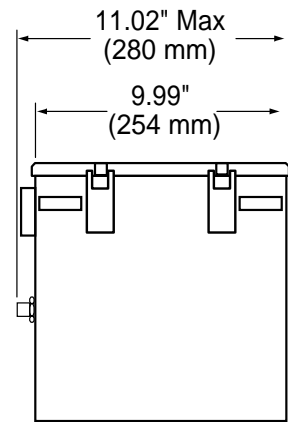
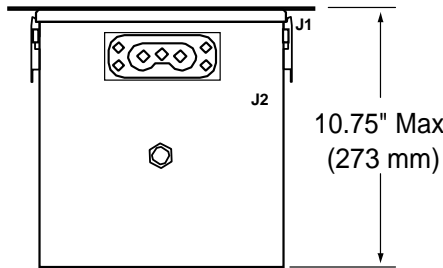
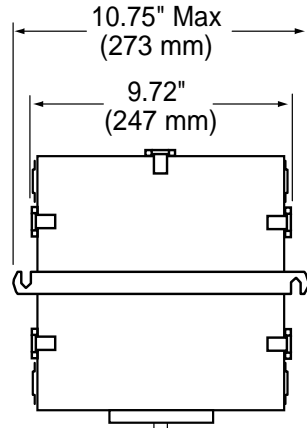

Information is subject to change. Please contact Securaplane for current data.

PERFORMANCE CURVES:

STORAGE OF UNCOMMISSIONED PRODUCT

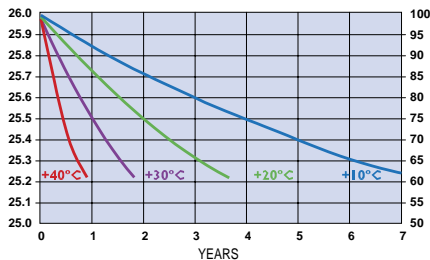

CHARGE ACCEPTANCE
BS 6G 205 Clause 8.11

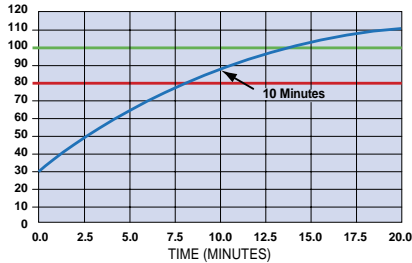

POWER RATING
Testing of Group B sample to Batspec 210
clause of 3.9 and IEC 952-1 clause 6
Test Reference PDTR 1817 - June 1998

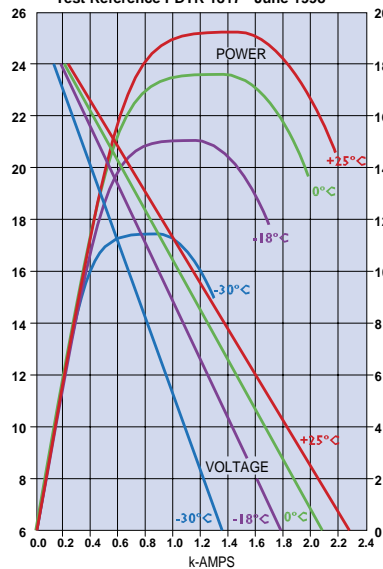

EASY REBLOCKING:



Internal monoblocks can be replaced at significant savings over the replacement cost of the battery.